

December 22, 2025

Special Use

Daniel Nakahara, AICP
Planner II
Village of Deerfield
850 Waukegan Road, Deerfield, IL 60015
847.719.7480

Re: Proposed Gloss Nail Bar
Deerbrook Shopping Center
92 S Waukegan Rd, Deerfield, IL 60015
Project Description

Dear Mr. Nakahara

Gloss Nail Bar is proposing to build our salon in the vacant retail space at 92 S Waukegan Ra, Deerfield, IL 60015. Gloss Nail Bar would provide the community with a luxury nail and spa for the local residents and will bring customers into Deerfield within 30 miles radius into Deerbrook shopping center.

We will take over the space and do a total renovation into a luxury nail salon. No modifications will be made to the exterior façade. The proposed new sinage will meet all local and Deerbrook signage requirements. The existing lighting, landscaping, and parking will remain the same. No new site improvements are proposed.

Gloss Nail Bar will bring a more customer based customers service to cater to clients coming into Deerbrook shopping center. While Deerfield is out 5th locations in the Illinois, we are associated with big brand like Milano Nail Spa and Nail of America (100 locations and counting, Coco Nail Bar (9 Locations), Venezia Nail Spa (10 locations), and much more. Our companies have build a lots of luxury Nail Salon in the Illinois region. Please see below for Gloss Nail Bar Founder and as a builder:

THINH TO

BUSINESS OWNER & BUILDER



SUMMARY

Business Owner with over 17 years experience in marketing, planning, construction, operation, and purchasing. Build and operated 27 nail salon, restaurant, and Café in the past 16 years. Possesses Bachelor in Computer Science and Certified in Business Management.

Contact Information

Mobile: (815) 608-6443

Email: thinhto@yahoo.com

thinhto@gmail.com

8808 Harvest Hills Trail

Rockford, IL 61114

EXPERIENCE

Business Owner & Builder

Salon Locations Build and Owner

- Gloss Nail Bar (Rockford)
- Blush Nail Lounge (Loves Park)
- Lush Nail Bar (Rockford)
- Blush Nail Bar (Roscoe)
- Coco Nails and Beauty (Loves Park)
- Essence Nail & Spa (Rockford)
- Milano Nail Spa (Broadview)
- Venezia Nail Spa (9 locations)
- Gloss Nail Bar – Coming Soon
 - *Machesney Park*
 - *Geneva Commons*
 - *Schaumburg*
 - *Deerfield*
 - *Cherry Valley*

Salon Locations as Builder

- Coco Nail Bar (9 locations)
- Ava Nail Bar (2 locations)
- L.A Nails (Loves Park)
- Happy Nails (Loves Park)
- Beauty Nails & Spa (Beloit, WI)
- Milano Nail Spa (Mount Prospect) – Coming Soon
- Lavish Nail Bar (Machesney Park)
- Royal Nails and Spa (Machesney Park)

SKILLS

- Salon Builder
- Marketing
- Business Operations
- Networking
- Leadership
- Team Building Skilled
- Delegation and Time Management

The proposed operations within our salon are designed to cater to a wide range of age ranges. We offer affordable services and also high end services to cater to everyone in the community. Our services would include pedicure, manicure, and nail related services. We have rooms to cater to appointments clients, walk-ins clients, and also private rooms for birthdays, parties, events. Our goals and dedication is to provide utmost satisfactory services with no clients leave the salon unhappy. We often donate to local events and charity to stay engaged and close to the community.

The typical hours of operations is Monday – Friday: 9AM-7PM, Saturday: 9AM-6PM, Sunday: 10AM-5PM. We do closed on all the National Holidays for our staff to enjoy time with their families.

The estimated numbers of client going into our salon is difficult to determine as nice weather season will bring more clients while bad weather will be much slower. During such the colder season, the Holidays will bring more clients into our salon.

Please see the break down below for the area of the facility. On the average during weekdays, 8-12 staff would work at one time. During the Weekend and Holidays, we would have 12-16 staff to work at one time. The proposed facility's gross square footage is 6,858.

| | |
|------------------------------|------------------------|
| Reception and Polish Station | 680 SF (Approximate) |
| Manicure Area | 1,200 SF (Approximate) |
| Pedicure Area | 2,421 SF (Approximate) |
| Customer Lounge | 480 SF (Approximate) |
| Bathrooms | 400 SF (Approximate) |
| Utility | 450 SF (Approximate) |
| Waxing Room | 224 SF (Approximate) |
| Hallway | 1,003 SF (Approximate) |

Gloss Nail Bar does not receive many deliveries. We will only have one anticipated deliveries every 2 weeks for our supplies to be brought to our salon.

The following list of items is excluded from this submittal as they are not applicable to the proposed buildout and are to be remains as is.

- Gloss Nail Bar does not propose to put any window signs at this location
- All services is to be done inside our salon
- The exterior landscaping on the property is to remain as is
- The existing rooftop mechanical equipment is to remain as is and is currently screened from view
- The trash area is to remain as is
- The parking lot lighting is to remain as is
- At this time, no proposed sustainable green design elements are being incorporated into this project, as the majority of the work is a Tenant build out
- There is no need for a bike rack for this proposed use.

SPECIAL USE CRITERIA

Does it meet the standards for a Special Use? A Special Use shall be authorized only when the Plan Commission finds all of the following:

1. Compatible with Existing Development

The nature and intensity of the activities involved and the size, placement and design of any structures proposed will be so planned that the Special Use will be compatible with the existing development and will not impede the normal and orderly development and improvement of surrounding property.

The facility will be located at 92 S Waukegan Rd, between Jewel and Marshall.

The Special Use will be compatible with the existing development and will not impeded the normal and orderly development and improvement of surrounding property.

2. Lot of Sufficient Size

The current lot will be plenty for Gloss Nail Bar clients and staff in the Deerbrook Shopping center.

3. Traffic

The location of the Special Use within the Village will be such that adverse effects on surrounding properties will be minimal, particularly regarding the traffic generated by the Special Use. This projected increase in daily and peak hour traffic is low and not anticipated to significantly impact operations and capacity along Lake Cook Road and Waukegan Road.

4. Parking and Access

Parking areas will be of adequate size for the particular use and properly. During our slow time, we anticipated to use 20 parking space and a maximum of 40 parking space at peak Summer time and during Holidays.

5. Effect on Neighborhood

In all respects the Special Use will not be significantly or materially detrimental to the health, safety and welfare of the public or injurious to the other property or improvements in the neighborhood, our salon will bring more values property values in the surrounding area.

6. Adequate Facilities

That adequate utilities, access roads, drainage and/or other necessary facilities have been or are being provided.

The Deerbrook Shopping Center is serviced by signalized access to Waukegan Road, which provides more than sufficient access. Existing utilities, drainage, and other necessary facilities that already service other uses in the center have been provided.

7. Adequate Buffering

Our operation is on inside the salon. We will not have excessive noise during our relaxation services. Our neighbors in Deerbrook shopping center will not be effected in any ways.

8. If in C-1 Village Center District: That the establishment of the Special Use will not be injurious to the character of the C-1 Village Center D

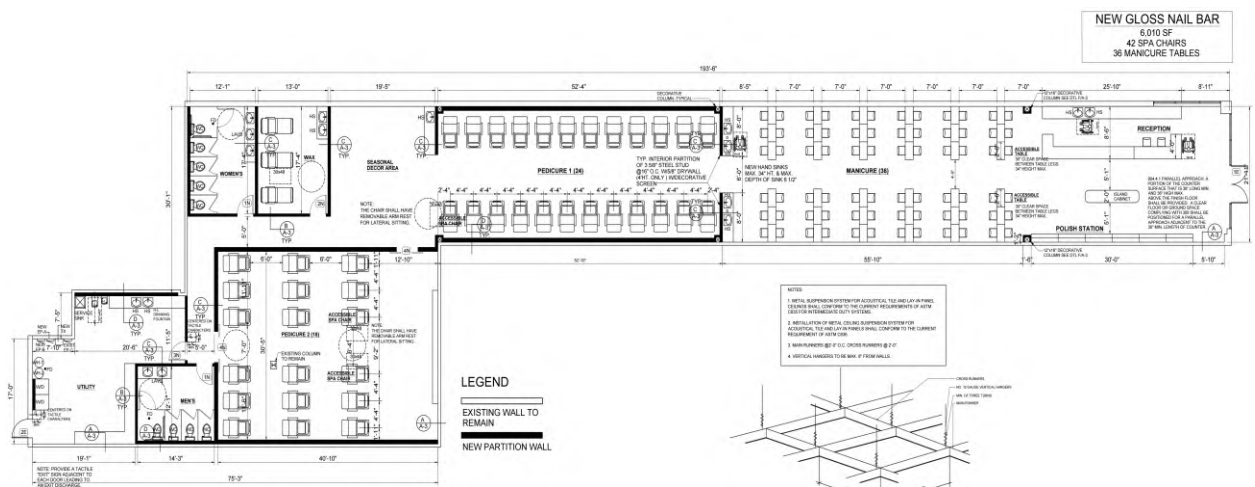









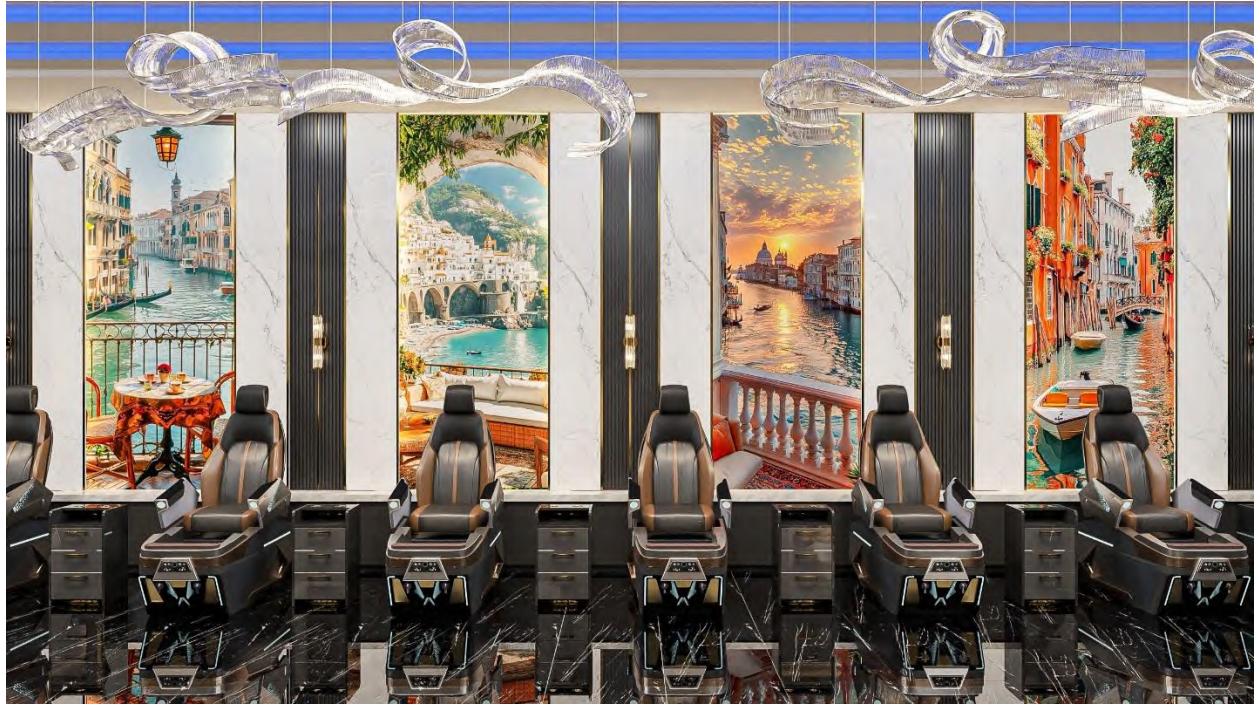







Project Name: Gloss Nail Bar Ext. Sign Package

Client: Think Hitto

Address: 94 S Waukegan Rd., Deerfield, IL 60015

Job #: 96210

Approved by: _____

Date: _____

Proof date: 02/18/2026

Version #: 5

Page: 1/6

Production cannot begin until this form is completed and returned to Signs Now

SCOPE OF WORK:
- Fabricate & install channel letters

SIGN TYPE:
- Face-lit channel letters

SIGN FONTS:
- Custom designed logotype

QUANTITY:
- 1 set

OVERALL SIZE (HxW):
- 48"x156"

LETTER BODY DEPTH:
- 3"

MOUNTING TYPE:
- Flush, fasteners through backs

LIGHTING TYPE:
- White LED

TRIM CAP COLOR/SIZE:
- 1", Black

RETURNS (SIDES) COLOR:
■ Black

FACE COLORS:
■ #2447 acrylic with day/night black perforated overlay
■ #2447 acrylic with Oracal 8800-091 Gold Translucent overlay with opaque black graphics



3" DEEP, FACE-LIT CHANNEL LETTER
TRIMCAP: 1" BLACK
BODY: BLACK
FACE: 2447 WHITE WITH PERFORATED BLACK OVERLAY

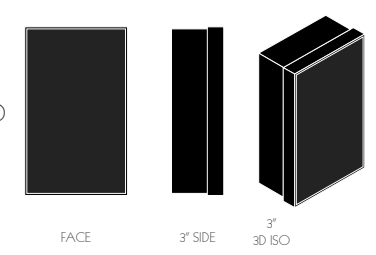

3" DEEP, FACE-LIT CHANNEL LETTER
TRIMCAP: 1" BLACK
BODY: BLACK
FACE: 2447 ACRYLIC WITH "GOLD NUGGET" OVERLAYS & BLACK OPAQUE GFX

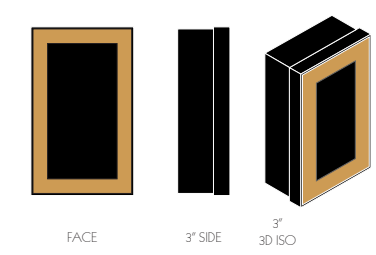

FACE LIT CHANNEL LETTERS
-3" DIRECT MOUNT-

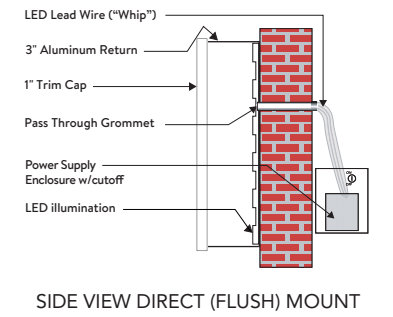
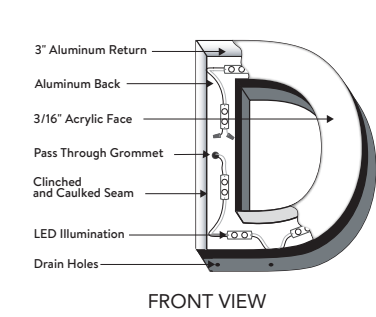

Preparatory materials: Artwork and other items, when supplied by SIGNS NOW, shall remain the exclusive property of SIGNS NOW unless otherwise agreed in writing.

Alterations: Requests for changes to the production proof are allowed; however, excessive alterations may require the project to be requoted, and numerous change requests may result in the addition of a design fee. Any changes made after proof approval will incur a fee.

ELECTRICAL SVC. REQUIREMENTS:
Number of circuits: 1
Voltage: 120 -or- 277 VAC
Amperage: 4.8@120VAC -or- 2.8@277VAC
Notes: Does not include timer or photocell unless otherwise spec'd



SIGNS NOW WILL MAKE FINAL CONNECTION TO A DESIGNATED ELECTRICAL CIRCUIT LOCATED WITHIN 5 FEET OF SIGN'S INSTALL LOCATION.
IF CIRCUIT IS UNAVAILABLE, IT IS THE CUSTOMER'S RESPONSIBILITY TO CONTRACT A LICENSED ELECTRICIAN TO ESTABLISH A PROPER CIRCUIT.



www.SignsNowRockford.com

700 20th St., Rockford, IL 61104 (815)398-8371

THIS SIGN IS INTENDED TO BE INSTALLED IN ACCORDANCE WITH THE REQUIREMENTS OF ARTICLE 600 OF THE NATIONAL ELECTRICAL CODE AND/OR OTHER APPLICABLE LOCAL CODES. THIS INCLUDES PROPER GROUNDING AND BONDING OF THE SIGN

Project Name: Gloss Nail Bar Ext. Sign Package
Client: Thinh Hitto
Address: 94 S Waukegan Rd., Deerfield, IL 60015
Job #: 96210

Approved by: _____ Date: _____

Proof date: 02/18/2026 Version #: 5 Page: 2/6

Production cannot begin until this form is completed and returned to Signs Now

Installation rendering with wall measurements:

LEASE LENGTH:
- 21'-11"

HEIGHT TO ROOF DECK:
- 21'-10"

Sign to be centered within the sign band



Preparatory materials: Artwork and other items, when supplied by SIGNS NOW, shall remain the exclusive property of SIGNS NOW unless otherwise agreed in writing.

Alterations: Requests for changes to the production proof are allowed; however, excessive alterations may require the project to be requoted, and numerous change requests may result in the addition of a design fee. Any changes made after proof approval will incur a fee.

ELECTRICAL SVC. REQUIREMENTS: Number of circuits: 1
Voltage: 120 -or- 277 VAC
Amperage: 4.8@120VAC -or- 2.8@277VAC
Notes: Does not include timer or photocell unless otherwise spec'd



SIGNS NOW WILL MAKE FINAL CONNECTION TO A DESIGNATED ELECTRICAL CIRCUIT LOCATED WITHIN 5 FEET OF SIGN'S INSTALL LOCATION.

IF CIRCUIT IS UNAVAILABLE, IT IS THE CUSTOMER'S RESPONSIBILITY TO CONTRACT A LICENSED ELECTRICIAN TO ESTABLISH A PROPER CIRCUIT.

THIS SIGN IS INTENDED TO BE INSTALLED IN ACCORDANCE WITH THE REQUIREMENTS OF ARTICLE 600 OF THE NATIONAL ELECTRICAL CODE AND/OR OTHER APPLICABLE LOCAL CODES. THIS INCLUDES PROPER GROUNDING AND BONDING OF THE SIGN

www.SignsNowRockford.com
700 20th St., Rockford, IL 61104 (815)398-8371

Project Name: Gloss Nail Bar Ext. Sign Package

Client: Thinh Hitto

Address: 94 S Waukegan Rd., Deerfield, IL 60015

Job #: 96210

Approved by:

Date:

Proof date: 02/18/2026 Version #: 5

Page: 3/6

Production cannot begin until this form is completed and returned to Signs Now

SCOPE OF WORK:

- Fabricate & install channel letters

SIGN TYPE:

- Face-lit channel letters

SIGN FONTS:

- Custom designed logotype

QUANTITY:

- 1 set

OVERALL SIZE (HxW):

- 42"x104"

LETTER BODY DEPTH:

- 3"

MOUNTING TYPE:

- Flush, fasteners though backs

LIGHTING TYPE:

- White LED

TRIM CAP COLOR/SIZE:

- 1", Black

RETURNS (SIDES) COLOR:

Black

FACE COLORS:

#2447 acrylic with day/night black perforated overlay



3" DEEP, FACE-LIT CHANNEL LETTER
 TRIMCAP: 1" BLACK
 BODY: BLACK
 FACE: 2447 WHITE WITH PERFORATED
 BLACK OVERLAY

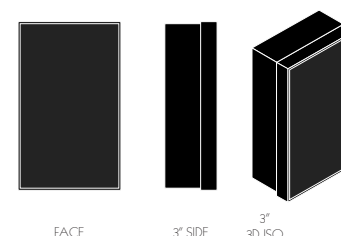

FACE LIT CHANNEL LETTERS
 -3" DIRECT MOUNT-

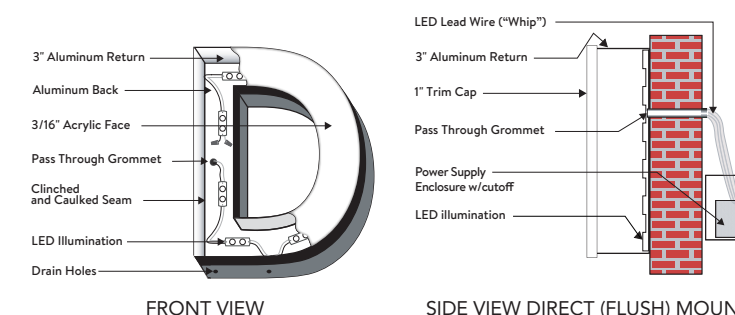

Preparatory materials: Artwork and other items, when supplied by SIGNS NOW, shall remain the exclusive property of SIGNS NOW unless otherwise agreed in writing.

Alterations: Requests for changes to the production proof are allowed; however, excessive alterations may require the project to be requoted, and numerous change requests may result in the addition of a design fee. Any changes made after proof approval will incur a fee.

ELECTRICAL SVC. REQUIREMENTS: Number of circuits: 1
 Voltage: 120 -or- 277 VAC
 Amperage: 3.6@120VAC -or- 2.1@277VAC
 Notes: Does not include timer or photocell unless otherwise spec'd



SIGNS NOW WILL MAKE FINAL CONNECTION TO A DESIGNATED ELECTRICAL CIRCUIT LOCATED WITHIN 5 FEET OF SIGN'S INSTALL LOCATION.

IF CIRCUIT IS UNAVAILABLE, IT IS THE CUSTOMER'S RESPONSIBILITY TO CONTRACT A LICENSED ELECTRICIAN TO ESTABLISH A PROPER CIRCUIT.

THIS SIGN IS INTENDED TO BE INSTALLED IN ACCORDANCE WITH THE REQUIREMENTS OF ARTICLE 600 OF THE NATIONAL ELECTRICAL CODE AND/OR OTHER APPLICABLE LOCAL CODES. THIS INCLUDES PROPER GROUNDING AND BONDING OF THE SIGN



www.SignsNowRockford.com

700 20th St., Rockford, IL 61104 (815)398-8371

Project Name: Gloss Nail Bar Ext. Sign Package

Client: Thinh Hitto

Address: 94 S Waukegan Rd., Deerfield, IL 60015

Job #: 96210

Approved by:

Date:

Proof date: 02/18/2026 Version #: 5

Page: 4/6

Production cannot begin until this form is completed and returned to Signs Now

Installation rendering with wall measurements:

HEIGHT TO ROOF DECK:
- 21'-10"

ROOF LINE
21'-10"

Sign to be centered within the sign band



Preparatory materials: Artwork and other items, when supplied by SIGNS NOW, shall remain the exclusive property of SIGNS NOW unless otherwise agreed in writing.

Alterations: Requests for changes to the production proof are allowed; however, excessive alterations may require the project to be requoted, and numerous change requests may result in the addition of a design fee. Any changes made after proof approval will incur a fee.

ELECTRICAL SVC. REQUIREMENTS:
 Number of circuits: 1
 Voltage: 120 -or- 277 VAC
 Amperage: 4.8@120VAC -or- 2.8@277VAC
 Notes: Does not include timer or photocell unless otherwise spec'd



SIGNS NOW WILL MAKE FINAL CONNECTION TO A DESIGNATED ELECTRICAL CIRCUIT LOCATED WITHIN 5 FEET OF SIGN'S INSTALL LOCATION.

IF CIRCUIT IS UNAVAILABLE, IT IS THE CUSTOMER'S RESPONSIBILITY TO CONTRACT A LICENSED ELECTRICIAN TO ESTABLISH A PROPER CIRCUIT.

THIS SIGN IS INTENDED TO BE INSTALLED IN ACCORDANCE WITH THE REQUIREMENTS OF ARTICLE 600 OF THE NATIONAL ELECTRICAL CODE AND/OR OTHER APPLICABLE LOCAL CODES. THIS INCLUDES PROPER GROUNDING AND BONDING OF THE SIGN



www.SignsNowRockford.com

700 20th St., Rockford, IL 61104 (815)398-8371

Project Name: Gloss Nail Bar Ext. Sign Package

Client: Think Hitto

Address: 94 S Waukegan Rd., Deerfield, IL 60015

Job #: 96210

Approved by: _____

Date: _____

Proof date: 02/18/2026

Version #: 5

Page: 5/6

Production cannot begin until this form is completed and returned to Signs Now

SCOPE OF WORK:

- Fabricate & install tenant panels

SIGN TYPE:

- CNC cut, push-thru acrylic panels

SIGN FONTS:

- Custom designed logotype

QUANTITY:

- 2pcs

PANEL MATERIAL:

- .080 aluminum

GRAPHICS MATERIAL:

- Translucent acrylic (3/4" protruding)

OVERALL SIZE (HxW):

- 29.75"x90"

MOUNTING TYPE:

- Color matched button head screws

FACE COLORS:

Matthews #13914 "Greysbank"

#7328 Pure white translucent
(same as "FLOOR & DECOR" lettering)



Preparatory materials: Artwork and other items, when supplied by SIGNS NOW, shall remain the exclusive property of SIGNS NOW unless otherwise agreed in writing.

Alterations: Requests for changes to the production proof are allowed; however, excessive alterations may require the project to be requoted, and numerous change requests may result in the addition of a design fee. Any changes made after proof approval will incur a fee.



www.SignsNowRockford.com

700 20th St., Rockford, IL 61104 (815)398-8371

Project Name: Gloss Nail Bar Ext. Sign Package

Client: Thinh Hitto

Address: 94 S Waukegan Rd., Deerfield, IL 60015

Job #: 96210

Approved by:

Date:

Proof date: 02/18/2026

Version #: 5

Page: 6/6

Production cannot begin until this form is completed and returned to Signs Now

Installation rendering:



Preparatory materials: Artwork and other items, when supplied by SIGNS NOW, shall remain the exclusive property of SIGNS NOW unless otherwise agreed in writing.

Alterations: Requests for changes to the production proof are allowed; however, excessive alterations may require the project to be requoted, and numerous change requests may result in the addition of a design fee. Any changes made after proof approval will incur a fee.



www.SignsNowRockford.com
700 20th St., Rockford, IL 61104 (815)398-8371